



CNC high performance slant bed lathe

F-Turn CNC

25x32" to 37x124"



- Heavy-duty spindle and 2-step ZF-gearbox (F-turn 330 CNC)
- 3-step gearbox (F-turn 485 CNC)
- Heavy-duty hydraulic-driven 12-pos. tool turret ensuring high positioning accuracy (F-turn 485 CNC)
- Heavy-duty hydraulic-driven 10-pos. tool turret ensuring high positioning accuracy (F-turn 330 CNC)
- 12-pos. hydraulic tool turret with live tools available (F-turn 330 CNC)
- Hydraulic pump to control 3-jaw chuck and tool turret operation
- F-turn 330 CNC machines can be equipped with steady rest for machining of long parts
- Spindle oil cooling - for efficient heat removal and spindle and gearbox temperature control (F-turn 485 CNC)
- Programmable hydraulic tailstock motion driven by servodrive. The system is controlled by CNC M-codes (F-turn 485 CNC)

| Specifications | | F-Turn CNC | | | | | | | |
|----------------------------|--------|--|-----------------------|-----------------------|------------------------|--|-----------------------|-----------------------|------------------------|
| | | 330/820 25" x 32" | 330/1560 25" x 61" | 330/2340 25" x 92" | 330/3100 25" x 122" | 485/1200 37" x 46" | 485/1700 37" x 66" | 485/2200 37" x 85" | 485/3200 37" x 124" |
| Swing over bed | mm | Ø660 (25.75") | | | | Ø970 (37.75") | | | |
| Swing over carriage | mm | Ø480 (18.5") | | | | Ø720 (28") | | | |
| Max. workpiece diameter | mm | Ø500 (19.5") | | | | Ø850 (33") | | | |
| Distance between centers | mm | 820 (32.28") | 1560 (61.41") | 2340 (92.13") | 3100 (122") | 1200 (46.5") | 1700 (66") | 2200 (85.5") | 3200 (124.5") |
| Chuck mount | | A2-8 [opt. A2-11] | | | | A2-11 [opt. A2-15, A2-20] | | | |
| Spindle bore diameter | mm | Ø102 (3.95") [opt. Ø165 (6.5")] | | | | Ø155 (6") [opt. Ø228 (8.8"), Ø305 (11.8"), Ø355, (14")] | | | |
| Max. bar diameter | mm | Ø89 (3.4") [opt. Ø116 (4.5")] | | | | Ø115 (4.5") [opt. Ø135, Ø205 (5.3, 8")] | | | |
| Speeds | rpm | 625-2500 | | | | 2-1500 | | | |
| Number of spindle speeds | # | 2 steps (ZF-gears) | | | | 3 steps | | | |
| Max. speed of live tool ** | rpm | 0-2000 | | | | 0-2000 | | | |
| Chuck diameter | mm | Ø300 (11.7) [opt. Ø380 (14.75")] | | | | Ø380 (14.75) [opt. Ø450 (17.5"), Ø610 (23.75"), Ø810 (31.5")] | | | |
| Number of positions | # | 10 [opt. 12] | | | | 12 | | | |
| Toolholder dimensions | mm | 32x32 (1.25x1.25") [opt. 25x25 (1x1")] | | | | 32x32 (1.25x1.25") | | | |
| Axial tool post dimensions | mm | Ø50 (2") | | | | Ø50 (2") | | | |
| Travels | X axis | 280 (10.75") | | | | 450 (425 + 25) (17.5+1") | | | |
| | Z axis | 885 (34.5") | 1630 (63.5") | 2400 (94.5") | 3165 (124.6") | 1200 (46.5") | 1700 (66") | 2200 (85.5") | 3200 (124.5") |

*The above specifications are subject to change without prior notice. No liability for printing mistakes. Machine may be shown with optional equipment. — ** Live tool optional

Optional configuration

- Tailstock with programmable motion (F-Turn 330 CNC)
- Automatic tool setting device
- C-axis with live tools
- Hydraulic chuck
- Mechanical chuck (F-Turn 485 CNC)
- Hydraulic 12-position turret (F-Turn 330 CNC)

Standard configuration

- Fanuc CNC control
- ZF gearbox (F-Turn 330 CNC)
- Manual tailstock (F-Turn 330 CNC)
- Tailstock with programmable motion (F-Turn 485 CNC)
- Work light
- Air cooler for electric cabinet
- Hydraulic 10-position turret (F-Turn 330 CNC)
- Hydraulic 12-position turret (F-Turn 485 CNC)
- Spindle oil cooling (F-Turn 485 CNC)
- Coolant system, 3 bar (44 psi)
- Chip conveyor
- Three-color warning light
- Automatic lubrication
- Tool kit
- Operation manual

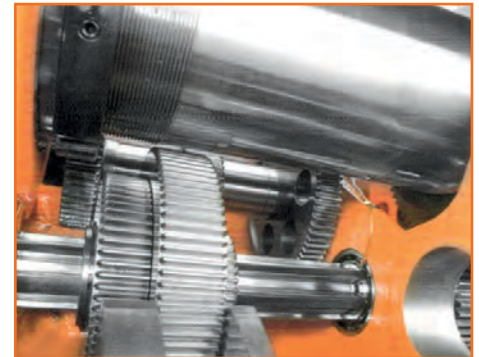
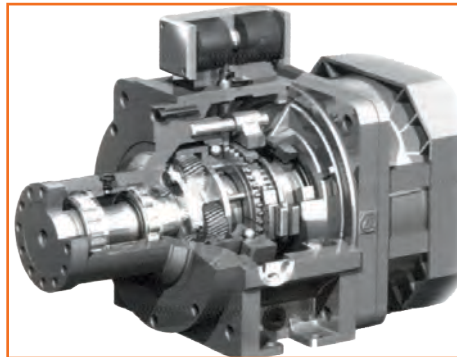
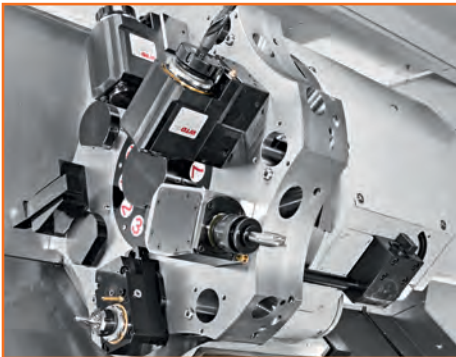
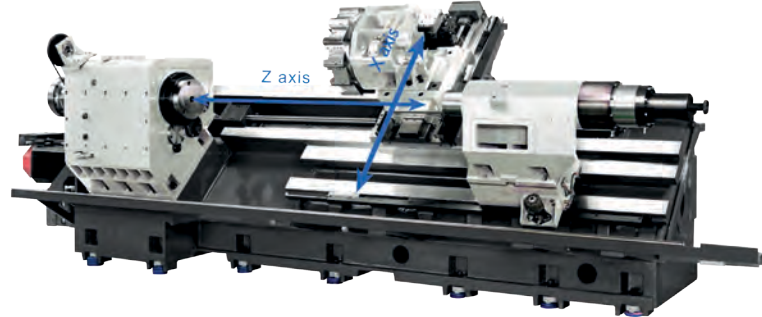
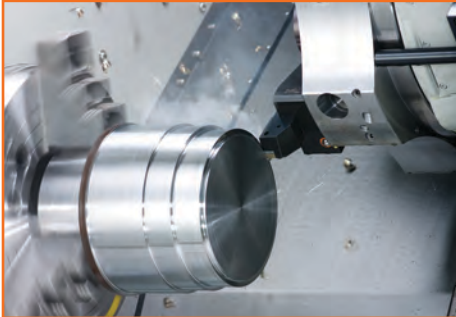

VDI 50 power turret (Option)

ZF gearbox (F-Turn 330 Series)

3-step gearbox (F-Turn 485 Series)

| Specifications | | F-Turn CNC | | | | | | | |
|---------------------------|--------|---------------------------------|-----------------------|-----------------------|-----------------------|---------------------------------|-----------------------|-----------------------|-----------------------|
| | | 330/820 | 330/1560 | 330/2340 | 330/3100 | 485/1200 | 485/1700 | 485/2200 | 485/3200 |
| | | 25" x 32" | 25" x 61" | 25" x 92" | 25" x 122" | 37" x 46" | 37" x 66" | 37" x 85" | 37" x 124" |
| Rapid traverse – X axis | m/min | 12 (468"/min) | | | | 12 (468"/min) | | | |
| Rapid traverse – Z axis | m/min | 15 (585"/min) | | | | 15 (585"/min) | | | |
| Cutting feed rates | mm/min | 0.001–500 (0.000039–19.68"/min) | | | | 0.001–500 (0.000039–19.68"/min) | | | |
| Motor spindle power | kW | 22/26 (30/35 Hp) | | | | 30/37 (40/50 Hp) | | | |
| Servo X-axis drive | kW | 4 (5.5 Hp) | | | | 4 (5.5 Hp) | | | |
| Servo Z-axis drive | kW | 4 (5.5 Hp) | | | | 4 (5.5 Hp) | | | |
| Hydraulic system motor | kW | 2.2 (3 Hp) | | | | 3.75 (5 Hp) | | | |
| Tailstock (Type) | | manual [opt. programmable] | | | | programmable | | | |
| Tailstock travel | mm | 780 (30") | 1540 (60") | 2300 (90") | 3060 (120") | 850 (33") | 1450 (56.5") | 1950 (76") | 2950 (115") |
| Tailstock quill travel | mm | 100 (3.9") | | | | 200 (7.8") | | | |
| Tailstock quill diameter | mm | Ø110 (4.3") | | | | Ø200 (7.8") | | | |
| Tailstock quill taper | | MT 5 | | | | MT 6 | | | |
| Hydraulic system capacity | l | 80 (21 gal) | | | | 80 (21 gal) | | | |
| Coolant tank | l | 140 (36 gal) | 200 (52 gal) | 260 (68 gal) | 320 (82 gal) | 230 (60 gal) | 265 (70 gal) | 295 (78 gal) | 360 (95 gal) |
| Dimensions (L) | mm | 5300 (208") | 6060 (239") | 6820 (269") | 7590 (299") | 6160 (240") | 6660 (260") | 7160 (280") | 8160 (319") |
| Dimensions (W/H) | mm | 2100x2235 (83x88") | | | | 2230x2445 (87x96") | | | |
| Weight | kg | 8870 (19,514 lbs) | 11300 (24,860 lbs) | 13700 (30,140 lbs) | 16000 (35,200 lbs) | 14200 (31,240 lbs) | 14950 (32,890 lbs) | 15700 (34,540 lbs) | 17200 (37,840 lbs) |
| Item No. | | 1630091 | 1630092 | 1630170 | 1630171 | 1630093 | 1630094 | 1630095 | 1630096 |

*The above specifications are subject to change without prior notice. No liability for printing mistakes. Machine may be shown with optional equipment. — ** Live tool optional