



Bed-type milling machine

DMV

10x50" to 20x87"

Machine features

- Vertical drilling and milling head swivel $\pm 45^\circ$ (250 B, 380 VS)
- Automatic spindle feed
- High quality MEEHANITE cast iron
- All guideways are coated with Turcite B
- XYZ slideways, table and T-slot are hardened and ground.
- Counter-balance for milling head
- Box ways on Y and column
- Telescopic steel cover to protect the slideway & ball screw from dust and coolant
- High grade casting is annealed & stress-released, providing high rigidity and wear resistance.
- Semi-guarding is standard [opt. full guarding]



DMV 500 VS



3-axis digital readout (DRO) is included



DMV 250 B



Rotary of inner spindle taper



Parallelism table



Squareness column/table horizontal



Parallelism T-slots



Squareness column/table vertical



Squareness column/table vertical



Squareness Spindle/table surface



Parallelism traverse/table surface



Rotary of spindle

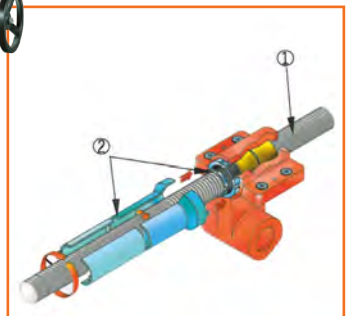

1. Double nuts are made of PBC phosphor bronze
2. Adjustable ball nut

Standard configuration:

- 3-axis digital readout
- Work light
- Telescopic cover in all axes
- Automatic feed in all axes
- Automatic lubrication
- Ergonomic swiveling control panel
- Coolant system
- Tool kit
- Operation manual

Optional configuration:

- Pneumatic drawbar
- Automatic feed in Y-and Z-axis (DMV 250 VS)
- Machine vise
- Chucking assortment

*The above specifications are subject to change without prior notice. No liability for printing mistakes. Machine may be shown with optional equipment.



Fagor 8055i CNC control is an available option

Mitsubishi CNC control system is standard for CNC machines



DMV 380 VS CNC

Standard configuration (CNC)

- Mitsubishi E70 CNC
- Variable speed spindle
- Ballscrews with double nuts on all 3 axes
- RS-232
- Automatic lubrication
- Work light
- Tool kit
- Operation manual

Optional configuration (CNC)

- Fagor/Siemens/ Fanuc controls
- 10,000 rpm
- 4th axis
- Air drawbar



Precision ballscrews are used on X&Y axes. (CNC)

Hi/Low speed gear drive spindle for powerful cutting performance (CNC)



Specifications		DMV				
		250 B 10" x 50"	380 VS 15" x 50"	450 VS 18" x 71"	500 VS 20" x 87"	
Table dimensions (W/L)	mm	1270x250 (50x10")	1270x380 (50x15")	1800x450 (71x18")	2200x500 (87x20")	
Max. table load	kg		600 (1,320 lbs)	1000 (2,200 lbs)	1000 (2,200 lbs)	
Travels	X	mm	775 (31")	1000 (39")	1300 (51")	1600 (63")
	Y	mm	540 (21")	500 (20")	600 (24")	700 (28")
	Z	mm	450 (10")	500 (20")	700 (28")	700 (28")
Spindle taper		NST #40		NST#50 Gear head		
Speeds	rpm	60-4300	50-3600 (CNC: 5000)	125-1100 (CNC: 5000)		
Tailstock quill travel	mm	127 (5")		140 (5.5")		
Power feed	mm/min	optional	½ Hp XYZ	1 Hp XYZ	2 Hp XYZ	
Swivel range milling head	deg		45°		-	
Spindle-table distance	mm	100-550 (4-22")	85-585 (3-23")	100-800 (3.9-31")	70-770 (2.8-30")	
Spindle-column distance	mm	500 (20")	490 (19")	580 (23")	700 (28")	
Main drive motor	kW	3.7 (5 Hp)		7.5 (10 Hp)		
Dimensions (L/W/H)	mm	1800x1600x2050 (71x63x81")	2050x2250x2100 (81x89x83")	2930x2750x2435 (115x108x96")	2930x3200x2530 (115x126x100")	
Weight	kg	2000 (4,410 lbs)	3100 (6,820 lbs)	3960 (8,730 lbs)	4500 (9,920 lbs)	
Item No.		2910091	2910019	2910092	2910093	
Item No. (CNC)		2910080	2910081	2910082	2910083	

*The above specifications are subject to change without prior notice. No liability for printing mistakes. Machine may be shown with optional equipment.